

ICFVL Ledger Connector System

NEW! The ICFVL Ledger Connector System is engineered to solve the challenges of mounting wood or steel ledgers to insulated concrete form (ICF) walls. Simpson's new ICF component of the system, the ICFVL, is designed to provide both vertical and lateral, in-plane performance. The system is still quick, versatile and easy to use but now provides so much more! There are many benefits over traditional anchor bolting, including better on center spacing in most cases, faster installation and no protrusions.

Simpson's ICFVL is made from galvanized, 14 gauge steel. The embedded legs are embossed for additional stiffness and the hole allows for concrete to flow through and around the connector. The exposed flange on the face of the ICF provides a structural surface for mounting either a wood or steel ledger.

MATERIAL: ICFVL—14 gauge; ICFVL-CW and ICFVL-W—16 gauge

FINISH: Galvanized

INSTALLATION: ICFVL in ICF

- Snap a chalk line for the bottom of the ledger.
- Mark required on center spacing.
- Use ICFVL to mark kerfs locations.
- Cut kerfs as marked.
- Insert ICFVL flush to the face of the ICF.
- Place concrete.

Wood Ledger Attachment – ICFVL-W or -CW

- Slip appropriate ledger connector underneath the ledger.
- Install the eight ICF-D3 screws partially into the ledger.
- Position the ledger level to the chalk line and drive the screws through the wood and into the ICFVL.

Steel Ledger Attachment

- Position the ledger level to the chalk line and against the ICFVL.
- Attach with four 1/4-14x3/4", #3 drill point screws (*not provided*).
- All screws should be located at least 1/2" from the edge of the ICFVL.
- Space screws evenly.

CODES: See page 12 for Code Listing Key Chart.

WARNING:
Industry studies show that hardened fasteners can experience performance problems in wet environments. Accordingly, use this product in dry environments only.

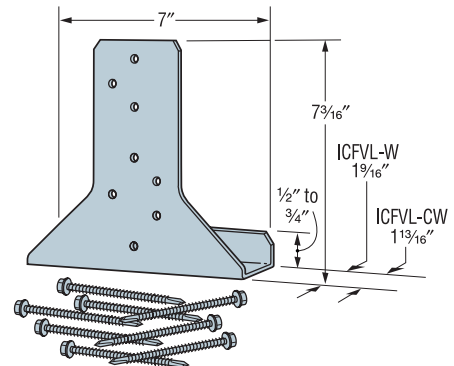
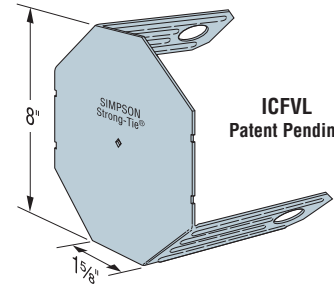

ICFVL-W and ICFVL-CW

Ledger Type	Fasteners	Allowable Load (lbs)	
		Download (100/115/125)	Lateral F ₁ (133/160)
Wood	8-ICF D3	1940	1905
Steel	4 - 1/4x3/4 ³	1660	1525

1. Fasteners for wood ledger (D3) are provided with the part and fasteners for steel ledger are not provided.
2. Loads apply to ICF foam thicknesses of 2% or less. Contact Simpson for allowable loads on thicker walls.
3. Alternately, #14 x 3/4" fastener may be used.
4. Tabulated loads may not be increased.

5. Concrete f'c = 2500 psi minimum.
6. When combining download and lateral loads, Designer shall evaluate as follows:
Design Download/Allowable Download + Design Lateral Load/Allowable Lateral Load.

These tables address vertical load applications only.

Ledger Type	Connector Type	ICFVL SPACING TO REPLACE ANCHOR BOLTS (in.) ^{1,2,3}																Code Ref.
		1/2" Dia. Anchors at				5/8" Dia. Anchors at				(2)-5/8" Dia. Anchors at				3/4" Dia. Anchors at				
		12" o.c.	24" o.c.	36" o.c.	48" o.c.	12" o.c.	24" o.c.	36" o.c.	48" o.c.	12" o.c.	24" o.c.	36" o.c.	48" o.c.	12" o.c.	24" o.c.	36" o.c.	48" o.c.	
WOOD LEDGERS																		
DF/SP/SPF	ICFVL w/ ICFVL-W	48	48	48	48	43	48	48	48	21	42	48	48	39	48	48	48	160
LVL	ICFVL w/ ICFVL-CW	48	48	48	48	43	48	48	48	21	42	48	48	39	48	48	48	
STEEL LEDGERS																		
68 mils (0.068")	ICFVL	11	22	33	44	9	18	27	36	—	—	—	—	—	—	—	—	160
54 mils (0.054")	ICFVL	15	30	45	48	12	24	36	48	—	—	—	—	—	—	—	—	

1. The Designer may specify different spacing based on the load requirements.
2. Spacings are based on perpendicular to grain capacity of bolt in wood ledger compared to tested value of ICFVL.
3. See F-ICFVL filer for additional connection details.
4. For steel ledgers, the 68 mil ledger spacing is closer than the 54 mil ledger because the calculated load of a bolt is higher in a thicker piece of steel.
5. Steel ledger values are based on steel. F_u = 60 ksi.

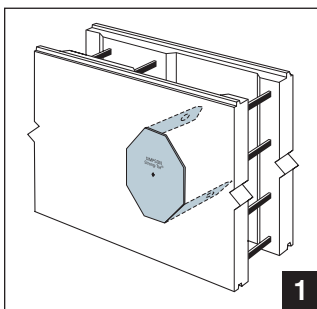

ICFVL

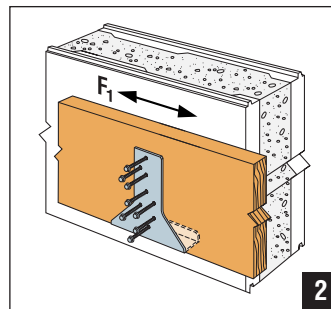

Typical Wood Ledger Installation with ICFVL and ICFVL-W

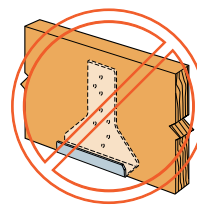

MISINSTALLATION!

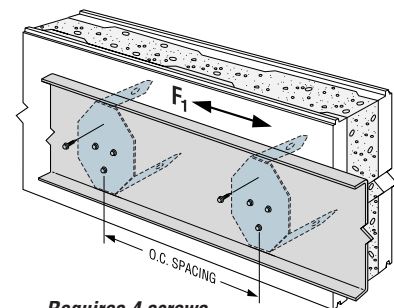

Requires 4 screws at each location. Table provides on center spacing.